



DIRECT GAS-FIRED MAKE-UP AIR UNITS MODEL SERIES MCV/MVV



TABLE OF CONTENTS



Modine offers a complete line of indoor and outdoor direct gas-fired make-up air units, which is summarized in Table 2.1.

This catalog describes in detail the Model Series MCV/MVV Direct Fired Make-Up Air Units. Included are product design benefits, construction features, performance data, control applications, as well as the available options and accessories.

Table 2.1 - Modine Direct Fired Make-Up Air Unit Product Portfolio ①

Unit Type	Unit Orientation	Typical CFM Range				
		800-1,600	1,600-14,000	14,000-30,000	30,000-45,000	45,000-60,000
100% Outside Air	Horizontal	MCV/MVV			MDB	
			MDB			
	Vertical		MDB			
Recirculating	Horizontal		MRB			

① Actual airflow range capability depends on a number of factors, primarily related to total static pressure the blower must overcome. For information on the MDB/MRB units, please refer to the latest revision of Catalog 7-150 or the Breeze® AccuSpec selection program.

Table of Contents

	Page
Product Overview	3
Performance Capabilities	3
Standard and Optional Design Features.....	4
Model Nomenclature Description	5-7
Factory Installed Options.....	8-11
Control Cabinet.....	8-10
Blower Cabinet.....	11
Side Access Filter Section	12
Field Installed Accessories	14-15
Factory Installed Evaporative Cooler Option.....	16-17
Dimensions.....	18-21
Unit Only (no Evap Cooler or Side Access Filter Section)	18
Unit with Side Access Filter Section	19
Evap Cooler	20
Inlet Hood and Roof Curb.....	21

WARNING

Do not locate ANY gas-fired unit in areas where chlorinated, halogenated or acid vapors are present in the atmosphere.

WARNING

Do not install in potentially explosive or flammable atmosphere laden with dust, sawdust, or similar airborne materials.

As Modine has a continuous product improvement program, it reserves the right to change design and specifications without notice.



Figure 3.1 - Model Series MCV/MVV



Introduction

Modine Direct Fired Make-Up Air Units are ideal for applications that require 100% outside air. Direct-fired units provide the best fuel efficiency (100% thermal efficiency, 92% sensible). The make-up air is heated directly by the gas flame, eliminating the need for a heat exchanger and associated efficiency losses experienced with indirect-fired equipment.

Model Series MCV/MVV units provide maximum application flexibility with input ratings up to 2,100,000 Btu/Hr and a wide range of airflow capability from as low as 800 CFM up to 14,000 CFM. The units are available with two model prefixes:

- **MCV:** Direct Fired, 100% Outside Air, Constant Speed Fan
- **MVV:** Direct Fired, 100% Outside Air, Variable Speed Fan
(provides reduction from rated speed down to 35%)

For full performance capabilities, refer to Table 3.1.

Product Overview

The Modine Model Series MCV/MVV product line has been designed to provide value through best-in-class features to simplify installation and reduce maintenance costs.

Standard Value-Added features include:

- Competitive pricing to provide low initial cost.
- Standard neoprene vibration isolated blower and motor for quiet operation.
- Auto-Velocity™ profile system constantly and automatically adjusts a burner profile bypass damper to maintain proper burner air velocity for optimal combustion.
- Prewired 10 foot long power and control wiring harnesses provided in flexible conduit simplifies electrical connections.
- Floor chase for wire routing to the space without having to drill holes in the unit floor.

Optional Value-Added factory installed features include:

- Galvanized interior double wall liners for ease of cleaning.
- Side access filter options to ensure delivery of clean air.
- LonWorks or BACnet MS/TP compatible controls for maximum centralized unit control.
- Hinged access doors for easy service access.
- Inlet and/or burner pressure gauges to quickly identify pressure without a manometer.

Table 3.1 - Robust Performance Capabilities ①

Casing Size (Digit 4)	Blower Size (Digits 5,6)	Airflow Range (CFM)		Max Air Temp Rise (°F)		Maximum MBH		Max Supply Air Temp (°F)
		Min.	Max.	Natural Gas	Propane Gas	Natural Gas	Propane Gas	
1	08	800	2,200	130	95	239	185	120
2	10	1,400	3,500	130	95	346	270	120
	12	2,400	3,500	130	95	375	375	120
3	15	3,200	8,000	130	95	938	907	120
4	18	5,000	9,500	130	95	1,428	1,077	120
5	20	5,500	14,000	130	95	2,100	1,587	120

① Maximum Btu/Hr based on Max CFM and Temp Rise (where possible) with -30°F entering air. Actual capability may vary with different job conditions. Please refer to our online Breeze® AccuSpec selection program with specific conditions.

Figure 4.1 - Standard Design Features, Options, and Accessories



Standard Features:

- ETL certification for use in the US and Canada for 100% outside air make-up air applications
- DWDI forward-curved fans for 800-14,000 CFM against a total static pressure of up to 3.0" W.C.
- Maximum 130°F temperature rise for natural gas (95°F for propane gas) and 120°F maximum supply air temperature
- 100% thermal efficiency (92% sensible)
- Corrosion resistant G90 galvanized steel casing panels on an extruded aluminum-tube cabinet frame
- Left side controls access (when looking into the inlet)
- Horizontal cabinet with down, straight, or top discharge
- Rigid channel base suitable for curb, slab, or suspension mounting. Includes integral lifting/suspension points
- Lift-out gasketed access panels with handles
- 1" foil-faced fiberglass insulation
- Maxitrol Series 14 discharge temperature control with factory mounted discharge air sensor
- Remote control panel with lights, switches, and temperature controls
- Low maintenance aluminum cast burner with stainless-steel mixing plates and 30:1 turndown capability
- Direct spark ignition up to 1125 MBH, interrupted pilot ignition 1200 MBH and larger
- Natural or propane gas fuel options
- Flame safeguard control with flame rod flame supervision and low fire start
- Auto-Velocity™ profile system constantly and automatically adjusts a burner profile bypass damper to maintain proper burner air velocity for optimal combustion
- High limit safety control
- Control step down transformer(s)
- Motor starter with overload protection
- Drive motor with adjustable sheave (fixed on blower)
- Fan bearings rated for L10 life (100,000 hours min.)
- Neoprene vibration isolation for fan and motor
- Non-fused disconnect switch
- Installation wiring harnesses in flexible conduit (10 feet standard for power wiring and 10 feet standard for remote panel wiring)
- Floor mounted chase eliminates drilling holes for wiring
- 100% factory tested in all modes of operation

Optional Features - Factory Installed

- Right side control access cabinet
- Hinged access doors (pictured on filter section in Figure 4.1)
- Painted cabinet (Modine Gray Green)
- Galvanized interior double wall liners (option to be painted)
- Filtered and non-filtered inlet hood
- Side access 2" filter section (permanent, MERV 8 throwaway, or MERV 13 throwaway)
- Motorized inlet damper (standard or low leak, power or spring return)
- Variable frequency drive control of supply fan motor
- Cabinet ventilation and/or heating for extreme ambient environments
- Maxitrol 44 (modulating space temperature control), Maxitrol SC11 (4-20mA or 0-10Vdc external control), or Honeywell SPYDER controller with LonWorks or BACnet MS/TP communication protocol
- Control relays (must specify function)
- Fused disconnect switch
- Inlet gas pressure gauge, burner gas pressure gauge, and/or high/low gas pressure switches
- Factory Mutual or GE GAP compliant manifolds
- Pillow block bearings on Casing Sizes 1 through 4 (standard on Casing Size 5)
- Extended grease lines on pillow block bearings
- Rubber-in-shear or spring vibration isolation for fan and motor
- Convenience outlet (power by others or power by unit)
- Evaporative cooling with or without pre-filters

Accessory Features - Field Installed

- Motorized discharge damper (standard or low leak, power or spring return)
- Discharge diffusers (3-way or 4-way)
- Full unit perimeter roof curb with nailer for flat roof installation (insulated or non-insulated)
- Timed freeze protection
- Mild temperature inlet thermostat
- Smoke detector
- Mechanical or digital timeclocks (7-day programmable)
- Vibration isolation hangers (for suspended units) or feet (for base mounted units)

MODEL NOMENCLATURE DESCRIPTION



Model Nomenclature Description

The following section details the 23 digit model number.

Digits 1,2,3 - Product Type

MCV = Direct Fired, 100% Outside Air, Constant Speed Fan
 MVV = Direct Fired, 100% Outside Air, Variable Speed Fan

Digit 4,5,6 - Casing Size and Blower Wheel Size

Designates the Casing Size (1-5) and the Blower Size (08-20). Each has a defined airflow capability range.

Table 5.1 - Casing Size and Blower Wheel Sizes

Casing Size (Digit 4)	Blower Size (Digits 4,5)	Blower Size Description	Airflow Range (CFM)	
			Min.	Max.
1	08	10 x 8"	800	2,200
2	10	10 x 10"	1,400	3,500
	12	12 x 12"	2,400	3,500
3	15	15 x 15"	3,200	8,000
4	18	18 x 18"	5,000	9,500
5	20	20 x 20"	5,500	14,000

Digit 7 - Unit Configuration

Designates the discharge location and controls access side. The control side is determined by looking into the intake of the unit and then specifying the access side (right or left hand). Includes access to gas manifold compartment and electrical control wiring compartment. All units are horizontal orientation. See Figure 5.1.

Figure 5.1 - Unit Configurations - Graphical

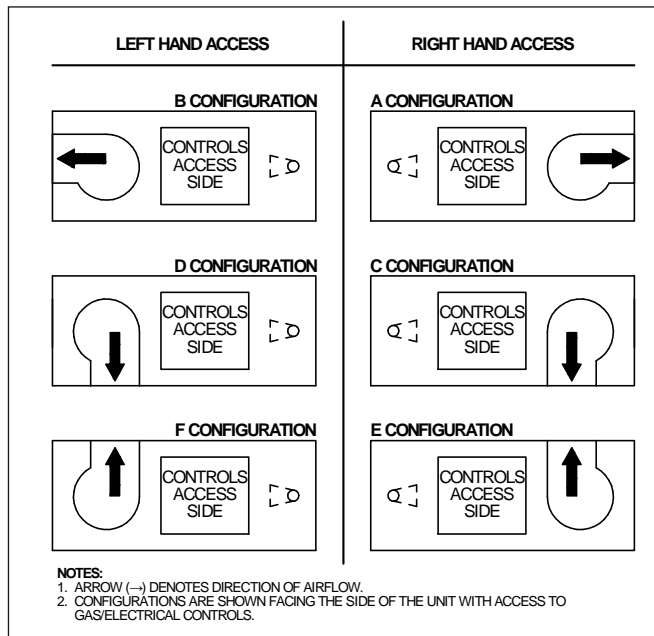

Digit 8 - Burner Type

The burner design used influences maximum temperature rise and turndown capability.

X = MAXON Series NP-LE AIRFLO

(Max temp rise of 130°F for natural gas, 95°F for propane)

Digit 9,10,11,12 - Maximum Input Capacity (MBH)

Manifold/burner combinations are sized based on available burner lengths and manifold component capabilities. The model number will reflect the maximum rating for the selected manifold/burner combination, however the actual firing rate will be set to meet actual job requirements.

Table 5.2 - Maximum Input Capacity

Digits 9-12	Maximum Input Capacity
290	290,000 Btu/Hr
375	375,000 Btu/Hr
625	625,000 Btu/Hr
750	750,000 Btu/Hr
938	937,500 Btu/Hr
1125	1,125,000 Btu/Hr
1200	1,200,000 Btu/Hr
1500	1,500,000 Btu/Hr
1875	1,875,000 Btu/Hr
2100	2,100,000 Btu/Hr

Example:

Unit is to be sized for a firing rate of 1,758,400 Btu/Hr (1758 MBH). The unit would be ordered with Digits 9-12 of the model number selected as 1875 (1500 MBH would be too small). When the unit is produced, it will be setup to have an actual capacity of 1758 MBH.

Digit 13 - Gas Type and Inlet Pressure

Specifies the gas type and gas inlet pressure being used. For inlet gas pressure higher than shown in Table 5.1, install a field supplied step-down pressure regulator.

N = Natural Gas, Standard Pressure (see Table 5.1)

P = Propane Gas, Standard Pressure (see Table 5.1)

Table 5.1 - Standard Inlet Gas Pressure Ranges

Digits 9,10,11,12	Inlet Pressure Range	
	Natural Gas	Propane Gas
	Digit 13=N	Digit 13=P
0290	8-14" w.c.	11-14" w.c.
0375		
0625		
0750	0.5-1psi	0.5-1psi
0938		
1125		
1200		
1500	0.5-5psi	0.5-5psi
1875		
2100		

Digit 14 - Gas Control System

The gas control system controls the burner firing rate of the unit. All gas control types offered feature electronic modulation.

A = Maxitrol System 14

System 14 features a remote temperature dial for adjusting the discharge air temperature set point and a factory installed discharge air sensor and controls to maintain the desired discharge air temperature. The temperature set point range for this system is 55-90°F.

This system can be used with a remote panel mounted room temperature override thermostat. The stat automatically overrides the discharge air temperature setting to provide warmer discharge air until the room override stat is satisfied.

B = Maxitrol System 44

System 44 features a modulating room thermostat to control the main burner firing rate based on the room air temperature set point. The temperature set point range for this system is 55-90°F.

This system also includes a factory installed discharge air sensor, which is used as a high and low temperature limit control. The discharge air sensor will prevent make-up air from being delivered to the space at temperatures below the low setpoint, even if the room thermostat is satisfied. It will also prevent the room thermostat from over firing the burner when mild outdoor temperatures exist and the maximum firing capacity of the burner is not required to achieve an appropriate discharge air temperature.

C = Maxitrol SC11 for 4-20mA Control

D = Maxitrol SC11 for 0-10VDC Control

The SC11 system utilizes a 4-20mA or 0-10VDC input signal (by others) to control the discharge air temperature.

This system includes a discharge air sensor high temperature limit control. The discharge air sensor will prevent make-up air being delivered to the space that is above the operating limit of 120°F.

L = Honeywell SPYDER Controller with LonWorks Protocol

M = Honeywell SPYDER Controller w/BACnet MS/TP Protocol

The SPYDER system is an advanced BMS compatible HVAC controller with either a BACnet MS/TP or LonWorks interface. The system includes an LCD remote that is easily navigated to provide access to all information needed to completely control, maintain, and troubleshoot the unit. All capabilities available at the remote are available over the network.

Digit 15 - Insurance Compliance

All standard manifold arrangements are ETL certified to meet the ANSI standards for direct fired make-up air units.

Optional manifold arrangements are available to meet the requirements of FM (Factory Mutual) or GE GAP (formerly IRI - Industrial Risk Insurers).

E = ETL (standard)

F = FM

G = GE GAP 4.3.1 (formerly IRI)

Digit 16 - Additional Manifold Options

Additional manifold options are available to provide either additional equipment protection, compliance with local code requirements, and/or enhanced serviceability.

N = None

A = Inlet Gas Pressure Gauge (IGPG)

An inlet gas pressure gauge provides visual indication of the incoming gas pressure to the unit. Units require a minimum pressure to provide successful ignition and correct combustion performance.

B = Burner Gas Pressure Gauge (BGPG)

A burner gas pressure gauge provides visual indication of the gas pressure being delivered to the burner. Correct gas pressure to the burner is required to provide the firing rate capacity for the actual job design conditions. It also ensures proper flame performance at low fire conditions.

C = High and Low Gas Pressure Switches (HLGPS)

A high gas pressure switch monitors the gas supply pressure downstream of all the gas controls and disables the gas controls if high gas pressure is experienced immediately before the burner. This will shut off all gas flow to the burner to avoid the gas controls from being damaged or causing the unit to over fire.

A low gas pressure switch monitors the gas supply pressure upstream of all the gas controls and disables the gas controls if low gas pressure is experienced. This will shut off all gas flow to the burner to avoid the burner from having difficulty lighting properly or maintaining a proper flame.

Both the low and high gas pressure switches are manual reset so that a service person must inspect the unit to make sure that none of the gas controls have been damaged. The switch must then be reset to allow the unit to operate when the gas pressure is returned to the normal operating pressure.

D = IGPG and BGPG

Combination of options A and B above.

E = IGPG and HLGPS

Combination of options A and C above.

F = BGPG and HLGPS

Combination of options B and C above.

G = IGPG, BGPG, and HLGPS

Combination of options A, B, and C above.

Digit 17 - Ignition/Flame Safeguard System

Designates the ignition system and flame safeguard system used to maintain safe burner operation.

A = Direct Spark Ignition with Flame Rod Flame Supervision
(Standard on units up to and including 1125 MBH)

B = Interrupted Pilot Ignition with Flame Rod Supervision
(Standard on units 1200 MBH and larger)

Digit 18 - Supply Voltage

Indicates the supply voltage for the unit. A step down transformer may be included for reducing the supply voltage to either 24V or 115V for the unit controls.

1 = 115V/60Hz/1Ph

5 = 230V/60Hz/3Ph

2 = 208V/60Hz/1Ph

6 = 460V/60Hz/3Ph

3 = 230V/60Hz/1Ph

7 = 575V/60Hz/3Ph

4 = 208V/60Hz/3Ph



Digit 19 - Blower Bearings and Vibration Isolation

The blower assemblies are available in several configurations of bearing type and vibration isolation. All units feature neoprene vibration isolation as standard with several upgrades available, depending on the Casing Size of the unit selected.

A = Spider Bearings - Neoprene Vibration Isolation

Spider bearings include blower mounted bearing brackets with permanently lubricated ball bearings. Spider bearings are designed for use in low motor horsepower applications and are standard for Casing Sizes 1-4.

Neoprene vibration isolation provides basic isolation of the blower and motor from the base of the unit to minimize the transmission of vibration.

B = Pillow Block Bearings - Neoprene Vibration Isolation

Pillow block bearings include heavy-duty pillow block bearing housings with greasable internal ball bearings that are rigidly fastened to two blower support channels. Pillow block bearings are optional on Casing Sizes 1-4 and standard on Casing Size 5 units.

Neoprene vibration isolation provides basic isolation of the blower and motor from the base of the unit to minimize the transmission of vibration.

C = Spider Bearings - Spring Vibration Isolation

Spider bearings are as described above in option A.

The neoprene isolation is replaced by 1" deflection spring isolation providing a robust vibration isolation solution. This option is available on Casing Sizes 2-4.

D = Pillow Block Bearings - Spring Vibration Isolation

Pillow block bearings are as described above in option B.

The neoprene isolation is replaced by 1" deflection spring isolation providing a robust vibration isolation solution. This option is available on Casing Sizes 2-5.

E = Spider Bearings - Rubber-In-Shear Vibration Isolation

Spider bearings are as described above in option A.

The neoprene isolation is replaced by rubber-in-shear (R-I-S) isolation providing a robust vibration isolation solution that rivals spring isolation at a lower cost. This option is available on Casing Sizes 1-4.

F = Pillow Block Bearings - Rubber-In-Shear Vibration Isolation

Pillow block bearings are as described above in option B.

The neoprene isolation is replaced by rubber-in-shear (R-I-S) isolation providing a robust vibration isolation solution that rivals spring isolation at a lower cost. This option is available on Casing Sizes 1-5.

Extended grease lines are available as an option on units with pillow block bearings to allow for greasing of the bearings from outside the unit cabinet. Please see the Options section for additional information on this option.

For suspended or slab mounted units, field installed vibration hangers or feet are also available as a cost-effective vibration isolation solution. Please refer to the Accessories section for additional information.

Digit 20 - Motor Horsepower

The required motor horsepower is determined by the required CFM and total static pressure (internal + external static pressure) and varies based on the blower size selected in Breeze® AccuSpec.

Model MCV units include a factory installed motor starter with overload protection as standard. For model MVV units, the VFD replaces the motor starter.

A = 1/2	F = 3
B = 3/4	G = 5
C = 1	H = 7-1/2
D = 1-1/2	J = 10
E = 2	K = 15

Digit 21 - Motor Type

Blower motors are available in Open Drip Proof and Totally Enclosed styles. Motors rated for 3 phase voltages that are 1HP and larger are NEMA Premium Efficiency motors.

- 1 = Open Drip Proof (ODP)
- 5 = Totally Enclosed (TE)

Digit 22 - Cabinet Finish and Installation Location

Casings are made with G90 galvanized steel and can be provided as either unpainted or painted. Both can be specified for indoor or outdoor installations. Casing is insulated with 1" thick, 1-1/2 lb. density foil-faced insulation as standard with G90 galvanized liners available as an option.

- A = Unpainted, Outdoor Installation
- B = Unpainted, Indoor Installation
- C = Painted Exterior, Outdoor Installation
- D = Painted Exterior, Indoor Installation
- E = Painted Interior and Exterior, Outdoor Installation
(Requires Digit 23=2 for Double Wall Galvanized Liner Option)
- F = Painted Interior and Exterior, Indoor Installation
(Requires Digit 23=2 for Double Wall Galvanized Liner Option)

Digit 23 - Cabinet Insulation

All units are fully insulated as standard (walls, roof, and floor).

- 1 = 1" Fiberglass Insulation - Foil Faced
- 2 = 1" Fiberglass Insulation - Galvanized Double Wall Liners

Figure 8.1 - Standard Feature and Factory Mounted Option Locations - Control Cabinet

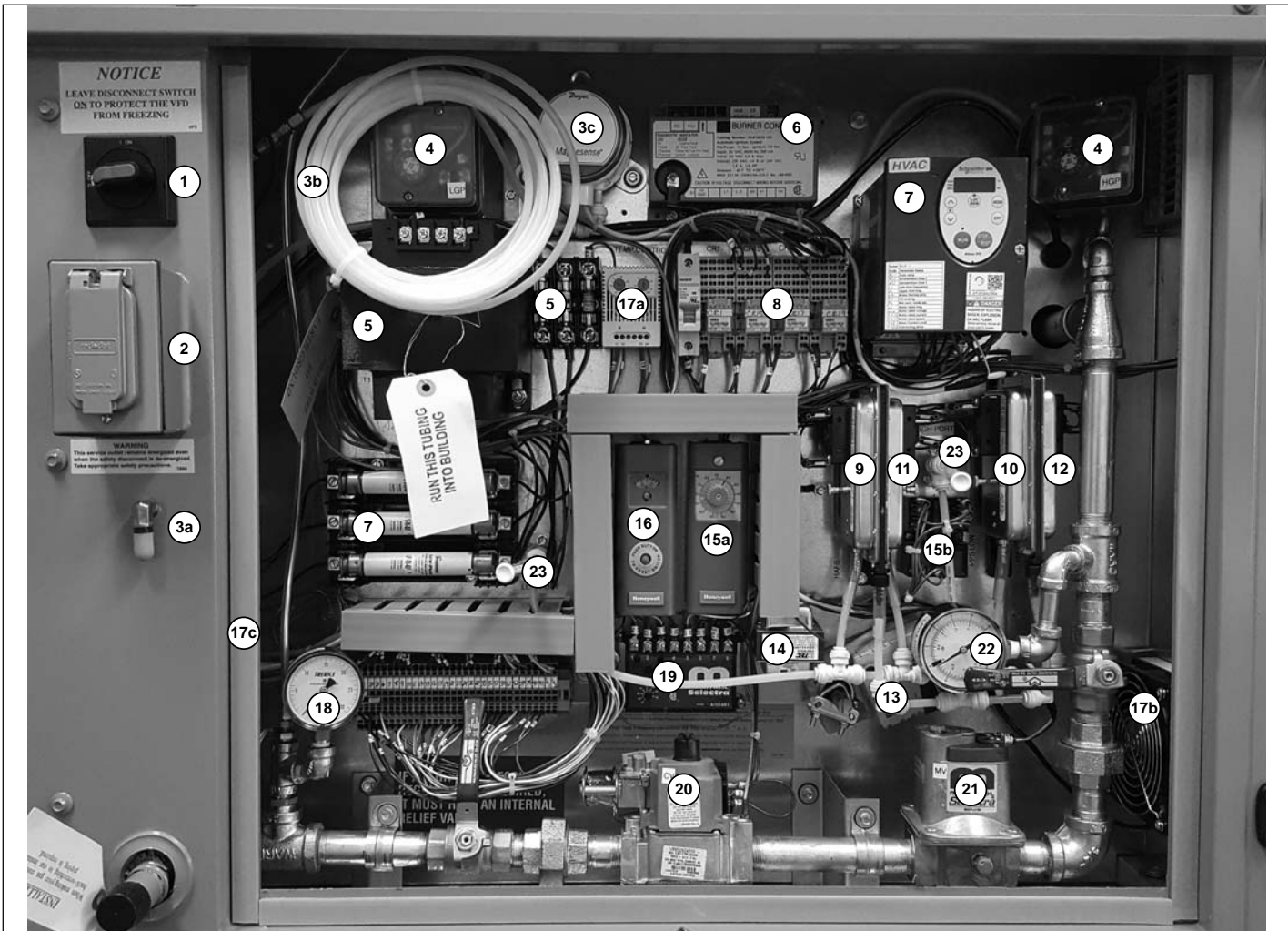

The following refer to Figure 8.1. These items are described in greater detail on the following pages. Note that (S) indicates a Standard feature and (O) indicates an Optional feature.

- | | |
|--|--|
| <ol style="list-style-type: none"> 1. (O) Non-Fused Disconnect Switch 2. (O) GFI Convenience Outlet 3. (O) Building Pressure Control, consisting of: <ol style="list-style-type: none"> a. Outdoor Pressure Pickup b. Indoor Pressure Pickup with Tubing c. Pressure Transmitter 4. (O) High and Low Gas Pressure Switches 5. (S) Control Power Transformer and Fuses 6. (S) Flame Safeguard Control 7. (O) Variable Frequency Drive 8. (O) Control Relay 9. (S) High Air Flow Cutoff Switch 10. (S) Low Air Flow Proving Switch 11. (S) High Profile Pressure Switch 12. (S) Low Profile Pressure Switch 13. (S) Profile Bypass Damper Motor | <ol style="list-style-type: none"> 14. (S) 24V Isolation Transformer 15. (O) Timed Freeze Protection, consisting of: <ol style="list-style-type: none"> a. Low Limit Discharge Duct Stat b. Freeze Protection Timer 16. (S) High Temp Limit Stat 17. (O) Cabinet Temperature Control, consisting of: <ol style="list-style-type: none"> a. Enclosure Mounted Thermostat b. Enclosure Cooling Fan c. Enclosure Heater 18. (O) Inlet Gas Pressure Gauge 19. (S) Temperature Control Amplifier 20. (S) Main Gas Valve 21. (S) Modulating Gas Valve 22. (O) Manifold Gas Pressure Gauge 23. (S) Profile Pressure Test Ports (Qty 2) |
|--|--|

The following details the standard and factory installed options available as shown in Figure 8.1. [(S)=Standard, (O)=Option]

1. (O) Non-Fused Disconnect Switch

Factory installed on the stationary panel next to the door provides convenient method of turning off power to the unit. Also available as fused.

2. (O) GFI Convenience Outlet

Includes a 115V/1ph duplex weatherproof service receptacle mounted on the exterior of the cabinet. Available as either powered by others (shown) or powered from unit (not shown). When powered by unit, the unit includes an additional unit mounted disconnect switch and step-down transformer for supply voltages above 115V.

3. (O) Building Pressure Control

This configuration is typically used to maintain a slightly positive pressure in the building to reduce infiltration. It is also used to provide variable volume make-up air for buildings that have multiple exhaust loads that cannot be interlocked to one make-up air unit. This option includes the following factory installed items:

- a. Outdoor Pressure Pickup
- b. Indoor Pressure Pickup with Tubing (route to space)
- c. Pressure Transmitter

The pressure transmitter monitors the space pressure relative to the outdoor air pressure and adjusts the VFD speed from full rated speed to as low as 35% of rated speed to bring in more or less outside air.

4. (O) High and Low Gas Pressure Switches

The low gas pressure switch monitors the gas supply pressure ahead of all the gas train components to ensure there is sufficient pressure for proper ignition. If the gas pressure is below the setpoint of the switch, the flame safeguard controller is disabled and the switch must be manually reset to allow the unit to function.

The high gas pressure switch monitors the gas pressure between the gas manifold components and the burner to ensure the gas pressure has not exceeded the maximum rating. Gas pressures above the maximum rating may damage the gas train components or cause the unit to overfire. If the gas pressure is above the setpoint of the switch, the flame safeguard controller is disabled and the switch must be manually reset to allow the unit to function.

5. (S) Control Power Transformer and Fuses

For supply voltages greater than 115V, a transformer is used to reduce the voltage for the unit controls.

6. (S) Flame Safeguard Control

The flame safeguard control monitors safety devices to determine if the gas ignition sequence should be initiated. Once initiated, the control will also monitor a flame rod flame sensor to ensure proper burner flame control. The control includes a pre-purge timer to clear any residual gas in the unit before ignition can be initiated. The ignition type varies by unit capacity as follows:

- Digits 9-12=0290-1125 MBH: Direct Spark
- Digits 9-12=1200-2100 MBH: Interrupted Pilot

7. (O) Variable Frequency Drive

Units with model number Digit 2=V are equipped with a factory installed VFD to provide control of air volume through varying the speed of the blower from 100% down to as low as 35%. The VFD can be programmed to provide any one of the following control configurations:

- **Constant Speed (field adjustable):** VFD will operate at full speed but can be adjusted in the field.
- **Two Speed:** VFD will operate at full rated speed or user defined low speed. The remote panel will include a High/Low speed switch for high/low speed changeover.
- **External 4-20mA or 0-10Vdc Control Signal:** VFD can be externally controlled from full rated speed down to 35% of rated speed. Unit includes terminals for landing external control wiring.
- **Building Pressure Control:** See option 3 note for information on this control configuration.

8. (O) Control Relay

Includes double-pole, double throw (DPDT) contacts for sequence of operation control switching. The function of the relays must be specified at the time of order.

9. (S) High Air Flow Cutoff Switch

The switch monitors the pressure drop across the burner to insure the air flow through the burner does not exceed the maximum design velocity. The switch is electrically interlocked with the flame safeguard control (#6).

10. (S) Low Air Flow Proving Switch

The switch monitors the pressure drop across the burner to insure that sufficient air flow exists before allowing the burner to operate. The switch is electrically interlocked with the flame safeguard control (#6).

Items 11 through 13 are part of the Auto-Velocity™ profile system that constantly and automatically adjusts a burner profile bypass damper to maintain proper burner air velocity for optimal combustion. The system has a range of operation to allow for correction of airflow changes from filters becoming dirty, changes in airflow when using a VFD, or slight changes in system duct static. It does not eliminate the requirement for proper system balancing at commissioning.

Please proceed to the following page for details on each component in this system.

The Auto-Velocity™ profile system components are as follows (refer to Figures 8.1 and 10.1):

11. (S) High Profile Pressure Switch

The switch monitors the pressure drop across the burner and if the pressure is too high (excessive airflow), the profile bypass damper motor (#13) is energized to adjust the profile balancing damper to allow more airflow to bypass the burner to reduce the pressure drop (velocity) to the acceptable range.

12. (S) Low Profile Pressure Switch

The switch monitors the pressure drop across the burner and if the pressure is too low (reduced airflow), the profile balancing motor (#13) is energized to adjust the profile balancing damper to allow less airflow to bypass the burner to increase the pressure drop (velocity) to the acceptable range.

13. (S) Profile Bypass Damper Motor

The damper actuator is directly coupled to the profile bypass damper and will increase or decrease the opening position based on changes in burner profile velocity as measured by the high and low profile pressure switches (#11 and #12).

Figure 10.1 - Auto-Velocity™ Profile System - Burner View

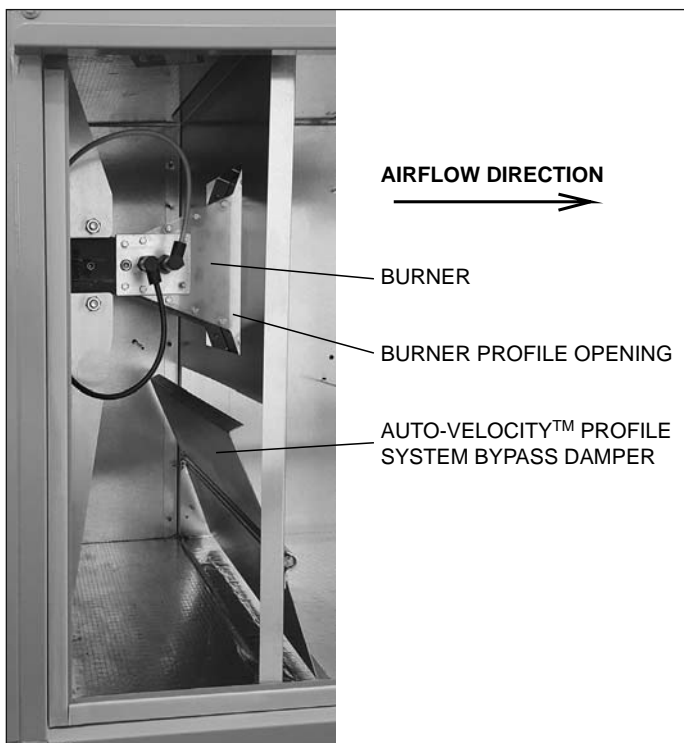

14. (S) 24V Isolation Transformer

A transformer, typically 115V to 24V or 24V to 24V is used to electrically isolate sensitive controls from the rest of the control circuit.

15. (O) Timed Freeze Protection

A low limit duct stat monitors the discharge air temperature, and if below the setpoint, the unit will shut down to prevent delivery of cold air. Includes the following:

a. Low Limit Discharge Duct Stat: The control is mounted in the control cabinet while the sensor is mounted in the blower cabinet (see Figure 11.1).

b. Bypass Timer: The 5 minute timer allows the unit to go through the normal start-up sequence while temporarily bypassing the low limit discharge duct stat.

16. (S) High Temp Limit Stat

The high temperature limit control prevents the burner from firing if excessive heated air temperatures are experienced. The limit control is mounted on the blower housing and is electrically interlocked with the flame safeguard control.

17. (O) Cabinet Temperature Control

Cabinet temperature control options are available for units with a factory mounted VFD. In extreme ambient temperatures, the temperature in the cabinet can impact the performance and longevity of the variable frequency drive. Includes some or all of the following:

a. Enclosure Mounted Thermostat: Activates heating and/or cooling fan operation as needed. Always included with either (b) or (c).

b. Enclosure Cooling Fan: Required for locations where the unit is in ambient temperatures 85°F and higher.

c. Enclosure Heater: Required for locations where the unit is in ambient temperatures below 0°F. For temperatures between 0° and 15°F, the heater is recommended but not required.

18. (O) Inlet Gas Pressure Gauge

The inlet gas pressure gauge option allows a contractor to easily determine if the gas pressure entering the unit is within the range required without having to connect an external manometer.

19. (S) Temperature Control Amplifier

The amplifier converts the temperature control signal from the discharge air temperature sensor (and room temperature sensor if the Maxitrol 44 system is used) and modulates the modulating gas valve (#20) to maintain the air temperature setpoint.

20. (S) Main Gas Valve

All units are supplied with redundant automatic main gas shut-off valves to control gas flow to the modulating gas valve (#21). These valves may be a combination gas valve as shown in Figure 8.1 which have two valve seats in one valve body (Digits 9-12=0625 and smaller), or two separate valves on units with larger capacities.

21. (S) Modulating Gas Valve

The modulating gas valve is controlled by the temperature control amplifier (#19) to control the flow of gas to the burner.

22. (O) Burner Gas Pressure Gauge

The burner gas pressure gauge option allows a contractor to easily determine if the gas pressure to the burner matches the manifold pressure listed on the serial plate to ensure the unit is firing at the correct capacity without having to connect an external manometer.

23. (S) Profile Pressure Test Ports (2)

Used during startup to easily connect a manometer to measure profile pressure drop during unit balancing.

Figure 11.1 - Standard Features and Factory Mounted Option Locations - Blower Cabinet

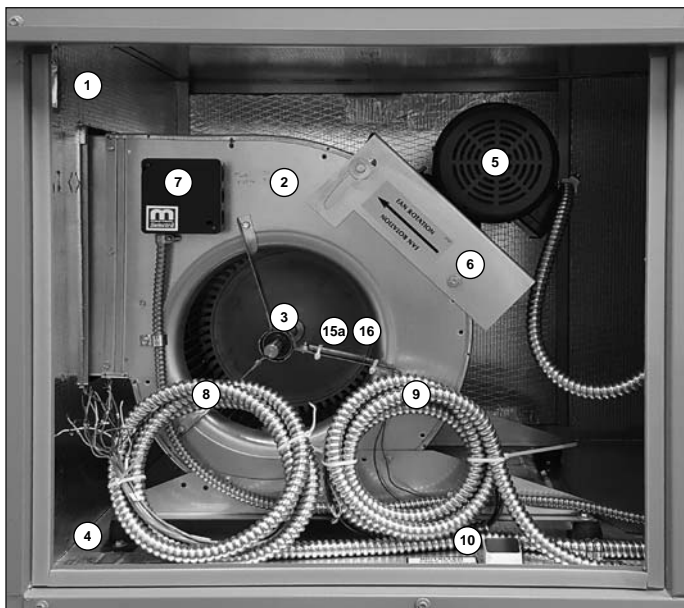

The following details the standard and factory installed options available as shown in Figure 11.1. [(S)=Standard, (O)=Option]

1. (S) Flame Observation Port

Provides visible indication of the flame and flame quality while the unit is operating and without needing to open the casing.

2. (S) DWDI Blower Wheel

Double Width, Double Inlet blower wheel with sizes as indicated on page 5.

3. (S) Blower Bearing Assembly

Most blower assemblies are available with either permanently lubricated spider bearings or greaseable pillow block bearings.

- **Spider Bearings:** Standard for Casing Sizes 1-4, not available on Casing Size 5. Spider bearings include blower mounted bearing brackets with ball bearings. Spider bearings are designed for use in lower torque applications as seen on the smaller blowers.
- **Pillow Block Bearings:** Optional for Casing Sizes 1-4, standard for Casing Size 5. The pillow block bearing option includes two heavy duty pillow block bearing housings rigidly fastened to two blower support channels. Pillow block bearings are available for all applications, but are required for high torque applications seen on larger blowers.

(O) Extended Bearing Grease Lines (not shown)

Extended grease lines are an available option for pillow block bearings. They include factory installed grease lines extending from the blower bearings to Zerk fittings on the outside of the unit cabinet.

4. (S) Blower/Motor Vibration Isolation

All units include neoprene blower/motor assembly vibration isolation as standard. For more robust vibration isolation, the following are options are detailed further on page 7:

- Rubber-In-Shear isolation on all sizes (see in Fig 11.1).
- Spring isolation on all except Casing Size 1.

5. (S) Supply Blower Motor

6. (S) Adjustable Motor Base

Provides adjustability of the motor position to ensure correct drive belt tension.

7. (S) Maxitrol Discharge Air Sensor

Standard for Maxitrol 14 and 44 gas controls systems, the sensor provides functions specific to the gas control type.

- **Maxitrol 14:** The sensor measures the discharge air temperature and provides feedback to the Maxitrol 14 controller to maintain the discharge air temperature setpoint by modulating the gas valve.
- **Maxitrol 44:** The sensor measures the discharge air temperature and provides feedback to the Maxitrol 44 controller to limit the modulation range so that temperatures do not fall outside the allowed range.

For more information, refer to page 6.

8. (S) Wiring Harness - Control Wiring

The 10 foot long pre-wired harness in flexible conduit allows for quick connection to the remote panel mounted in the space. The wires are numbered to correspond to a numbered terminal strip within the remote panel.

9. (S) Wiring Harness - Power Wiring

The 10 foot long pre-wired harness in flexible conduit allows for quick connection to the supply power for the unit.

10. (S) Floor Mounted Wiring Chase

Provides an easy pathway through the floor of the unit to route the Control and Power Wiring Harnesses to the space without needing to drill holes. See Figure 11.2.

Figure 11.2 - Floor Wiring Chase



15a.(O) Timed Freeze Protection

The timed freeze protection discharge sensor. See page 10 for a full description of this feature.

16. (S) High Temp Limit Stat

The high temp limit discharge sensor. See page 10 for a full description of this feature.

Figure 12.1 - Factory Mounted Options - Side Access Filter Section

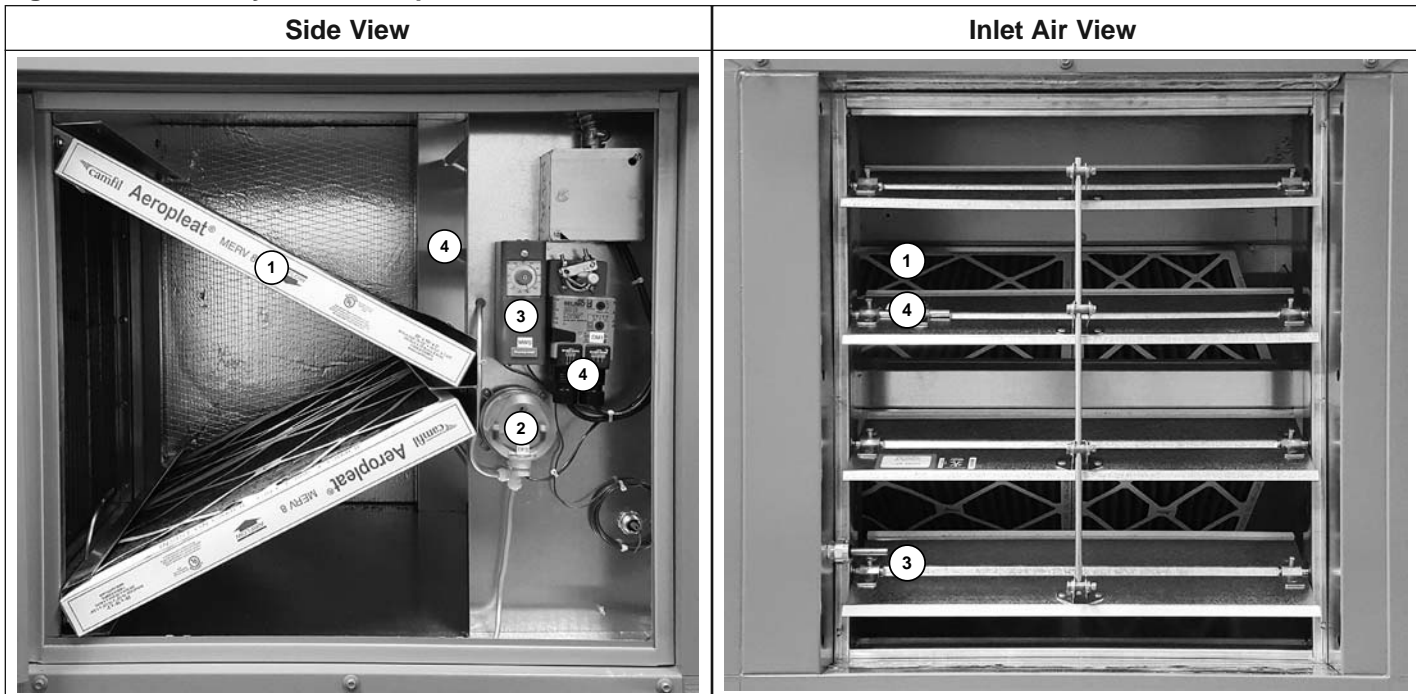

The following details the standard and factory installed options available as shown in Figure 12.1. [(S)=Standard, (O)=Option]

1. (O) Side Accessible Filters

The side access filter section is optional and is used to filter outside air drawn through the unit. Available either painted or unpainted to match the unit. The section is available with several filter configurations:

- 2" permanent, aluminum mesh washable filters
- 2" disposable MERV 8 pleated filters
- 2" disposable MERV 13 pleated filters

2. (O) Dirty Filter Switch

A differential pressure switch that measures the pressure drop across the filter media. When the pressure drop exceeds the setpoint, the switch closes which can be used to indicate the filters need to be serviced.

3. (O) Mild Temperature Inlet Duct Stat

Used to automatically shut off the burner when the inlet air temperature reaches the desired setpoint to prevent the burner from continually running at low fire during mild outdoor air temperature conditions.

4. (O) Inlet Dampers

Used to prevent building air from exiting the building through the unit when the unit is not operating. Both standard and low leak dampers are available. The inlet damper option includes a 2-position damper actuator that is available as either power or spring closed. The damper actuator includes an end switch to prevent unit operation unless the dampers are open.

Field installed discharge dampers are available. Please see Accessories section for additional details.

THIS PAGE INTENTIONALLY LEFT BLANK

Figure 14.1 - Typical Maxitrol 14 Remote Monitoring Panel

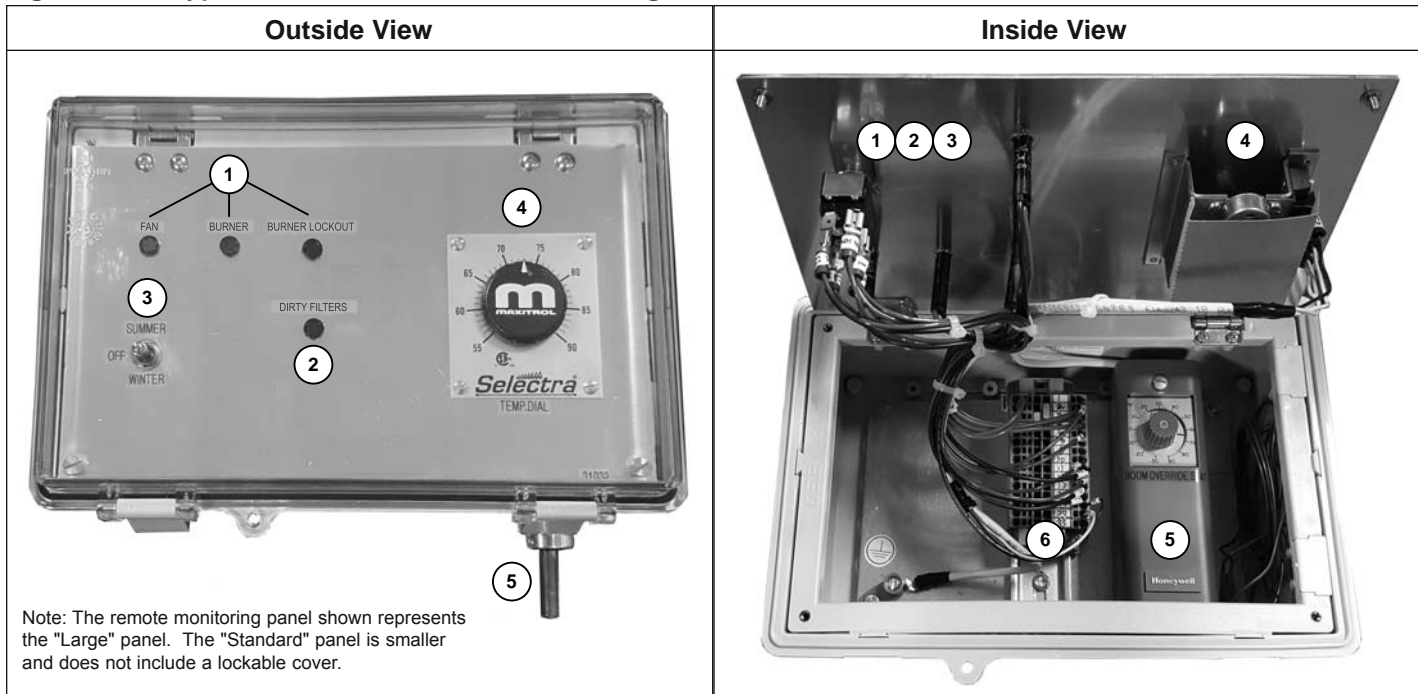

The following details the standard and factory installed options available as shown in Figure 14.1. [(S)=Standard, (O)=Option]

Remote Monitoring Panel

The remote monitoring panel is used to monitor/control the operation of the make-up air unit for all gas control types (model Digit 14=A, B, C, or D) except the Honeywell SPYDER control system (model Digit 14=L or M). Available panels are:

- **Standard Panel:** 4-3/8" H x 7-3/4" W x 2-3/8" D, rated NEMA 5 (satisfies NEMA 1, 2, and 5 requirements)
- **Large Panel:** 7-1/2" H x 10-1/2" W x 5-5/8" D, rated NEMA 4X (satisfies NEMA 1, 4, and 4X requirements), includes a clear polycarbonate lockable cover (Figure 14.1)

Remote monitoring panel features include:

1. (S) Standard Lights

The standard lights included with each panel are:

- **Fan:** Indicates if the fan is operating.
- **Burner:** Indicates if the burner is on.
- **Burner Lockout:** Indicates if there is a flame failure resulting in the burner being locked out of operation.

2. (O) Dirty Filters Light

The optional light indicates if the filters need to be cleaned or replaced. Requires a Dirty Filter switch (see Item 2 on page 12).

3. (S) Standard Switch

All panels include a Summer/Off/Winter switch that can be Summer (fan without heat), Winter (fan with heat), and Off (unit in standby).

3. (O) Optional Switch(es) (not shown)

Depending on the unit configuration, the remote panel may have additional switch(es). Other possible switches are:

- **Evap On/Off:** For units with an Evaporative Cooler.
- **High/Low:** Speed switch for units with 2-speed variable frequency drive motor control.

4. (S) Temperature Control

Depending on the unit configuration, the remote panel may have one of the following temperature controls:

- **Discharge Temp Setpoint Dial:** Maxitrol 14 units
- **Modulating Room Thermostat:** Maxitrol 44 units
- **None:** Maxitrol SC11 units

5. (O) Room Override Thermostat

Used only with Maxitrol 14 gas controls, the room thermostat automatically overrides the discharge air temp setting to provide warmer discharge air until the room override stat is satisfied. This option is only available on the Large remote panel.

6. (S) Wiring Terminal Strip

The wiring terminal strip provides an easy means of connecting the flexible conduit wiring harness from the unit (item 8 on page 11) to the remote panel. The wiring harness wires are numbered, as are the corresponding terminals on the terminal strip.

For information on units equipped with the Honeywell SPYDER Controller and LCD Interface module, see the following page.

Figure 15.1 - Honeywell SPYDER Controller/Interface

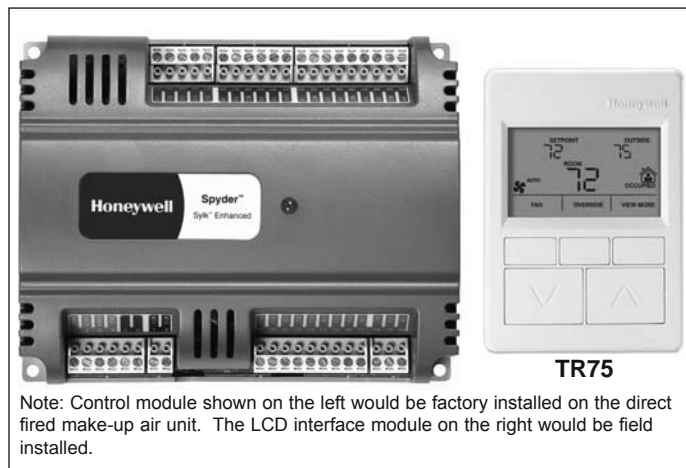

Honeywell SPYDER LCD Remote Panel

Available only on the Honeywell SPYDER controlled units (model Digit 14=L or M), the TR75 remote provides access to all information needed to control, maintain, and troubleshoot the unit. A few of the key features of this system include:

- Replaces the remote monitoring panel shown on page 14.
- A simple 2-wire terminal connection from the unit provides power and communications to the remote.
- Alarm codes indicate faults that can lock out the burner or unit, including mechanical and/or electrical issues.
- The network interface capability allows easy and cost effective connection to either a BACnet MS/TP or LonWorks building management system (BMS).
- All capabilities available at the remote are available over the network. Set point changes at the remote are reflected in the network points and vice-versa.
- No custom programming is required, only the configuration of network parameters.
- Electrical components and associated cost are reduced by integrating them into the controller programming.
- On loss of power all programming and set points are retained in flash memory for up to ten years.
- Sensors and outputs are always connected to the same controller terminals regardless of unit type, simplifying start-up, maintenance, and service.

Timeclock

A timeclock can be used for occupancy control to automatically turn the unit on during occupied periods and off during unoccupied periods. Two timeclocks are offered:

- **Programmable:** The programmable time clock is an electronic 7-day, 24-hour digital display electronic timer with battery backup. In addition to automatic on/off control, the timeclock can be programmed for other time-specific functions throughout the day and with different programs for each day of the week.
- **Mechanical:** The mechanical time clock does not allow the different sequences for different days of the week.

Smoke Detector

Low profile duct style photoelectronic smoke detector designed to detect the presence of smoke in the duct. Once the smoke is sensed, the smoke detector will de-energize the unit.

Inlet Hood

Used to prevent entry of rain into the fresh air opening of the unit and includes mesh bird screen on opening. Available either painted or unpainted and with or without 2" permanent aluminum mesh washable filters. Inlet hood is shipped knocked down for field assembly.

Discharge Damper

Used to prevent building air from exiting the building through the unit when the unit is not operating. Both standard and low leak dampers are available. The discharge damper includes a 2-position damper actuator that is available as either power or spring closed. The damper actuator includes an end switch to prevent unit operation unless the dampers are open. The damper is fully assembled but shipped loose for field installation. Discharge dampers are always painted.

Factory installed inlet dampers are available. Please see the Options - Factory Installed section for additional details.

Discharge Diffusers (3-Way or 4-Way)

The adjustable louvers provide either 3-way or 4-way control of discharge airflow direction. The assembly is factory assembled but shipped loose for field installation. Discharge diffusers are always painted.

Roof Curb (outdoor units only)

The roof curb is constructed of galvanized steel and is designed to support the unit and side access filter section (if equipped). The curb does not extend to the optional evaporative cooler (evaporative cooler is supplied with support legs). The curb is knocked down for field assembly and includes 1" x 4" nailer strips and curb to unit gasket material. Available with or without insulation. Roof curb is 20" tall.

Vibration Feet (Slab Mounted Units Only)

Used to provide vibration isolation, vibration feet consist of rubber-in-shear double deflection isolators with support mounting.

Vibration Hangers (Suspended Units Only)

Used to provide vibration isolation, vibration hangers consist of rubber-in-shear double deflection hanging isolators.



Evaporative Cooling Module

Outdoor units can be provided with a factory installed evaporative cooling module. When applicable, evaporative cooling is one of the most economical means of supplying conditioned air to a space.

The evaporative cooler used on the MCV/MVV Series units is a simplified, non-recirculating design that reduces up-front costs and maintenance. The cooler operation is explained in the description of the standard and factory installed options.

Benefits of the non-recirculating design are the following:

- A recirculation pump and float switch are not required.
- No sump required, reducing maintenance and water usage to reduce microbial growth that can occur from poorly maintained recirculating systems.
- There is a continuous wash-down of the media with fresh water to keep it flushed, increasing the lifespan of the media and reducing maintenance.
- There is reduced risk of freeze damage that can be seen with recirculating units with a sump.

Table 16.1 - Evaporative Cooler Performance Data

Unit Casing Size (Digit 4)	Evap Cooler Size	Max CFM	Media Area (sq. ft.)
1	EVCNR1	2,200	4.00
2	EVCNR2	3,500	5.78
3	EVCNR3	5,000	9.17
	EVCNR4	7,500	13.33
4	EVCNR4	7,500	13.33
	EVCNR5	9,500	20.00
5	EVCNR5	11,000	20.00
	EVCNR6	14,000	25.00

The following details the standard and factory installed options available as shown in Figures 14.1 and 14.2. [(S)=Standard, (O)=Option]

1. (S) Water Supply Connection

Includes a hand shut-off valve as standard. An accessory Water Supply Valve Kit (not pictured) is available that provides the following:

- Supply water valve (2-way)
- Supply line drain valve (2-way)
- Freeze stat

When ordered, this kit is shipped loose for field installation in a frost free environment (typically below the roof line). Refer to the Installation & Service Manual for additional details.

2. (S) Internal Water Control Valve (IWCV)

Valve controlled by the Liquid Level Controller (LLC) to allow water flow to the water distribution piping when wetted media is required.

3. (S) PVC Water Distribution Piping

The piping includes spray nozzles that uniformly distribute water on the face of the media.

4. (S) Evaporative Cooling Media

The standard media is Munters 12" CELdek® Cellulose evaporative cooling media.

For applications requiring UL 900, Class 2 fire rating and compliance with NFPA codes, optional Munters 12" GLASdek® Fiberglass media is offered. The media is accessible from the side access opening (media access cover removed for display purposes).

Figure 16.1 - Evaporative Cooler - Side Access

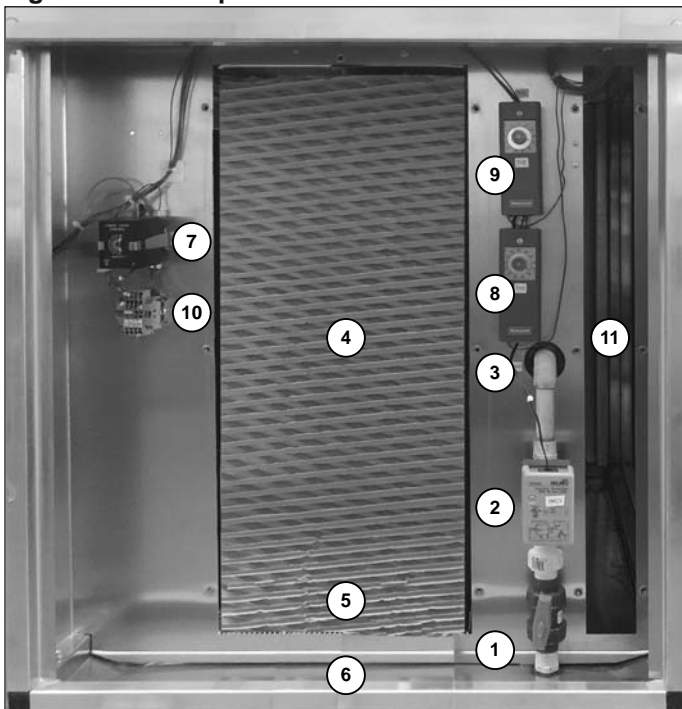

Figure 16.2 - Evaporative Cooler - Inlet Air Opening



5. (S) Overflow Water Sensor (OWS) (not shown)

On a call for cooling, the Liquid Level Controller (item 7) monitors the overflow water sensor, located at the bottom of the media, and opens the IWCV (item 2) to provide water flow to wet the media. When the OWS senses moisture, that is indication that the media is saturated and the LLC turns off the IWCV to conserve water.

6. (S) 304 Stainless Steel Casing and Pitched Drain Pan

Stainless steel offers outstanding corrosion resistance. Includes shipped loose adjustable leveling legs for support (not shown).

7. (S) Liquid Level Controller (LLC)

Controller that monitors the OWS (item 5) to determine if the IWCV (item 2) should be open or closed. Optimizes water consumption to avoid excessive water usage.

8. (S) Outdoor Air Thermostat

Measures the outside air temperature and if the temperature is above the setpoint, a call for cooling is initiated to the LLC (item 7).

9. (O) Freeze Stat

Measures the outside air temperature and if the temperature is below the setpoint, prevents the evaporative cooler supply water valve from being energized. This is part of the Water Supply Valve Kit discussed in item 1.

10. (S) Wiring Terminal Strip

The wiring terminal strip provides an easy means of connecting the flexible conduit wiring harness from the unit (item 8 on page 11) to the remote panel. The wiring harness wires are numbered, as are the corresponding terminals on the terminal strip.

11. (O) 2" Permanent Aluminum Mesh Pre-Filters

Optional pre-filters (not shown) can be added in the empty slot indicated by item 11. The filters are accessible from the side access opening (filter access cover removed for display purposes).

Also available as a field installed accessory (not shown) is an inlet hood that can be with or without 2" thick permanent aluminum mesh filters.

Evaporative Cooling Performance Example

Evaporative cooling works by placing a wet media in the entering air stream of the cooling unit. As the air passes through the media, sensible heat from the air is transferred to the water in the cooling media, causing the water to evaporate. Because the sensible heat from the air is simply transferred to the water, and both the water vapor and cooled air remain in the system, there is no net energy change in the system. However, the dry bulb temperature of the air has been lowered and provides cooling for the space.

The temperature of the cooling air will be dependent on three criteria. These criteria are:

- The design dry bulb temperature
- The design wet bulb temperature
- The percent effectiveness of the cooling media which is obtained from the media performance curve shown in Figure 17.1. The effectiveness is based on the velocity, which can be calculated by dividing the airflow in CFM by

the face area of the cooling media as shown in Table 16.1.

Example: Determine the final dry bulb temperature for a unit with Casing Size 4, rated airflow of 8000 CFM, installed in Phoenix, Arizona. Also, determine the approximate gallons per hour evaporated and the apparent cooling capacity of the evaporative cooler.

The following are the steps to determine the solution to the example problem above:

1. The 1.0% design conditions are 110°F DB/70°F WB.
2. There are two options for Casing Size 4 units shown in Table 14.1, however only one can be operated at 8000 CFM, the EVCNR5 unit. The Media Area is 20.0 ft². The air velocity is then calculated as follows:
FPM = CFM / Media Face Area = 8000 CFM / 20 ft² = 400 FPM
3. The media effectiveness is determined in Figure 17.1 (Y-axis) by finding where the effectiveness curve intersects 400 FPM velocity on the X-axis. In this example, the effectiveness is approximately 90%.
4. Determine final dry bulb air temperature of conditioned air by using the following formula:
LAT = EAT DB – (% Eff. x (EAT DB – EAT WB))
LAT = 110°F – (0.90 x (110°F – 70°F)) = **74°F DB**
5. The gallons per hour evaporated is calculated as follows:
G.P.H. = (1.2 x CFM x (EAT DB - LAT DB)) / 10,000
G.P.H. = (1.2 x 8,000 CFM x (110°F - 74°F)) / 10,000 = **34.6**
6. The cooling capacity, Q, of the unit is defined as the apparent cooling capacity because it is dependent on a specific set of temperature conditions. As these conditions change, so will the apparent cooling capacity. The formula is as follows:
Q = 1.08 x (EAT DB – LAT DB) x CFM
Q = 1.08 x (110°F – 74°F) x 8,000 CFM = **311,040 Btu/Hr**

Definition of Terms

- EAT = Entering Air Temperature
- LAT = Leaving Air Temperature
- DB = Dry Bulb
- WB = Wet Bulb
- % Eff. = Percent Effectiveness
- Q = Apparent Cooling Capacity

Figure 17.1 - Evaporative Cooler Effectiveness Curve

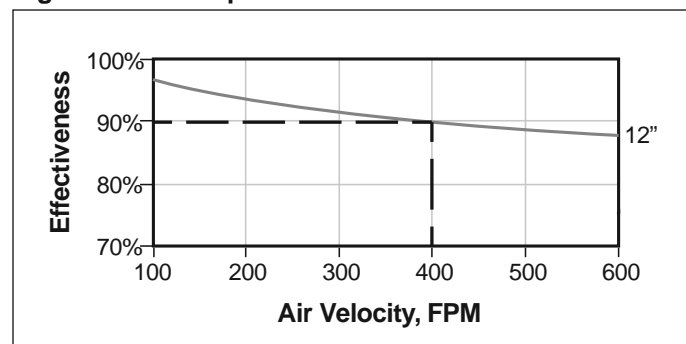
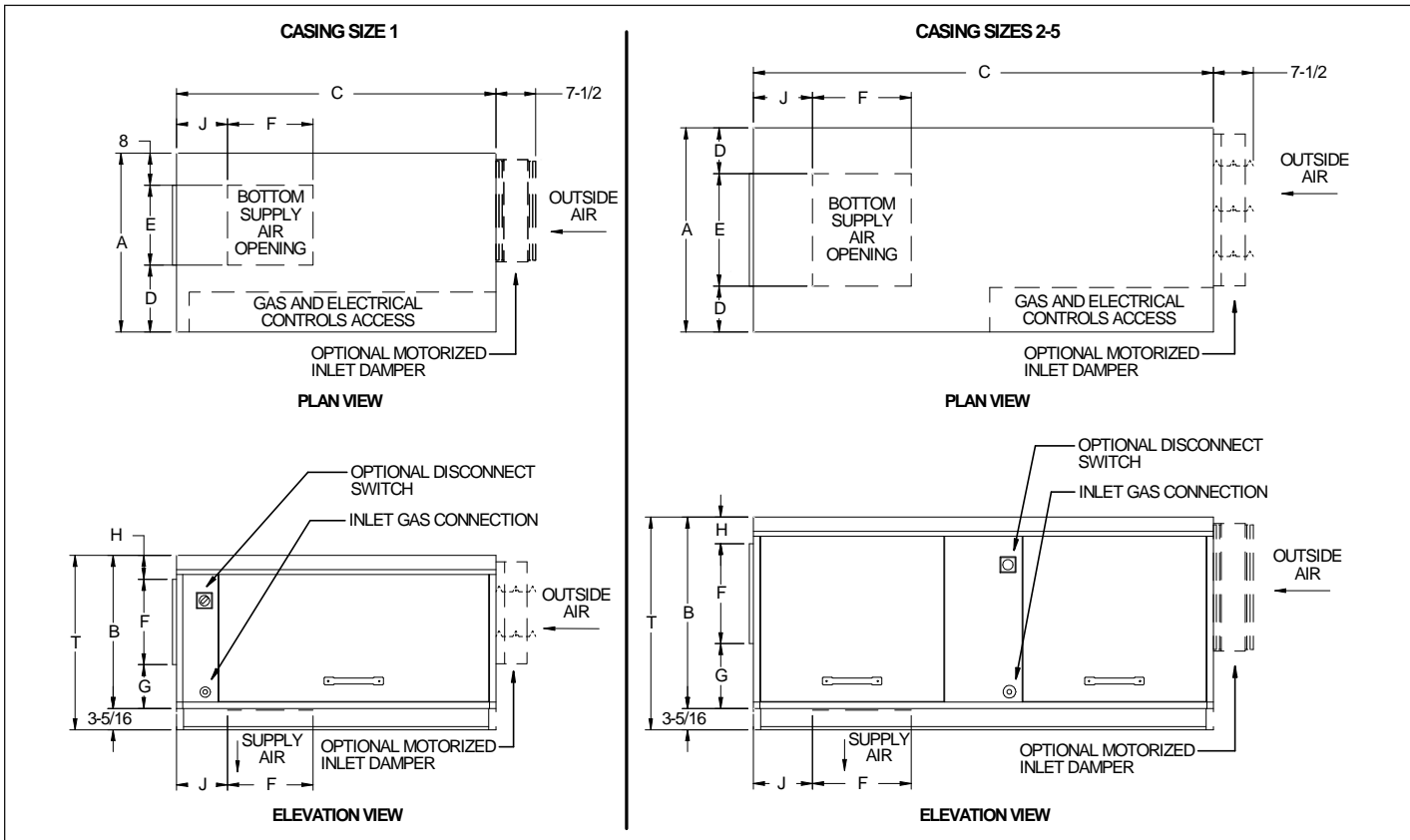

Figure 18.1 - Unit Dimensions (without Evap Cooler or Side Access Filter Section) (inches)



Note: The drawing above is a general drawing for both Unit Configurations (Digit 7) = "B" (Left Hand Access, Straight Discharge) and "D" (Left Hand Access, Bottom Discharge) for reference. For Unit Configurations other than "B" or "D", please see the Breeze® AccuSpec generated submittal package for the selected unit.

Table 18.1 - Unit Dimensions (without Evap Cooler or Side Access Filter Section) (inches)

Unit Size	A	B	C	D	E	F	Discharge Direction			S	T	Inlet Opening	
							Straight		Bottom or Top			N (Width)	U (Height)
							G	H					
108	28	24	50	10-1/2	12-1/2	13-3/8	6-7/8	3-3/4	8	N/A	N/A	19-7/8	22
210	32	30	72	8-7/16	15-1/8	13-3/8	6-7/8	9-3/4	8	N/A	N/A	22-7/8	28
212	32	30	72	7-3/16	17-5/8	15-7/16	8-1/4	6-5/16	9-1/4	N/A	N/A	22-7/8	28
315	40	33	92	9-11/16	20-5/8	17-7/8	9-3/8	5-3/4	10-1/2	N/A	N/A	28-7/8	31
418	48	38	96	12-1/16	23-7/8	20-7/8	11	6-1/8	12-1/4	N/A	N/A	36-7/8	36
520	55	48	96	14-1/8	26-3/4	26-3/4	12-15/16	8-5/16	13-1/2	N/A	N/A	43-7/8	46

DIMENSIONS - UNITS (with Side Access Filter Section)



Figure 19.1 - Unit Dimensions (with Side Access Filter Section) (inches)

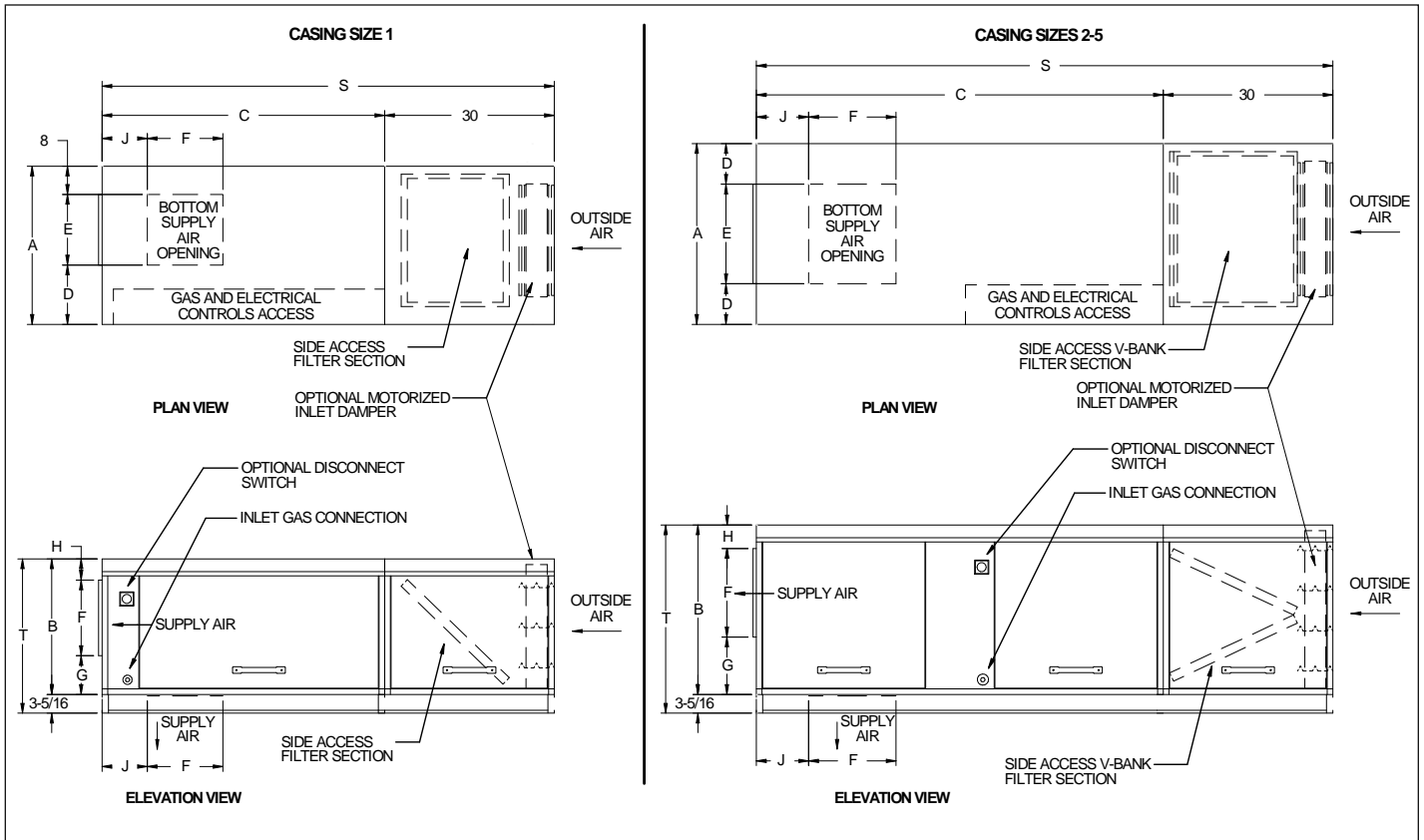

Note: The drawing above is a general drawing for both Unit Configurations (Digit 7) = "B" (Left Hand Access, Straight Discharge) and "D" (Left Hand Access, Bottom Discharge) for reference. For Unit Configurations other than "B" or "D", please see the Breeze® AccuSpec generated submittal package for the selected unit.

Table 19.1 - Unit Dimensions (with Side Access Filter Section) (inches)

Unit Size	A	B	C	D	E	F	Discharge Direction			S	T	Inlet Opening	
							Straight		Bottom or Top			N (Width)	U (Height)
							G	H					
108	28	24	50	10-1/2	12-1/2	13-3/8	6-7/8	3-3/4	8	80	27-5/16	19-7/8	22
210	32	30	72	8-7/16	15-1/8	13-3/8	6-7/8	9-3/4	8	102	30-5/16	22-7/8	28
212	32	30	72	7-3/16	17-5/8	15-7/16	8-1/4	6-5/16	9-1/4	102	30-5/16	22-7/8	28
315	40	33	92	9-11/16	20-5/8	17-7/8	9-3/8	5-3/4	10-1/2	122	36-5/16	28-7/8	31
418	48	38	96	12-1/16	23-7/8	20-7/8	11	6-1/8	12-1/4	126	41-5/16	36-7/8	36
520	55	48	96	14-1/8	26-3/4	26-3/4	12-15/16	8-5/16	13-1/2	126	51-5/16	43-7/8	46

Table 19.2 - Side Access Filter Dimensions (inches)

Model Size	Qty	Size	Model Size	Qty	Size
108	1	20" x 25" x 2"	315	3	16" x 20" x 2"
210	2	20" x 12" x 2"	418	3	20" x 20" x 2"
	2	16" x 20" x 2"		520	4
212	2	20" x 12" x 2"	520		8
	2	16" x 20" x 2"			

DIMENSIONS - EVAPORATIVE COOLER



Figure 20.1 - Evaporative Cooler Dimensions (inches)

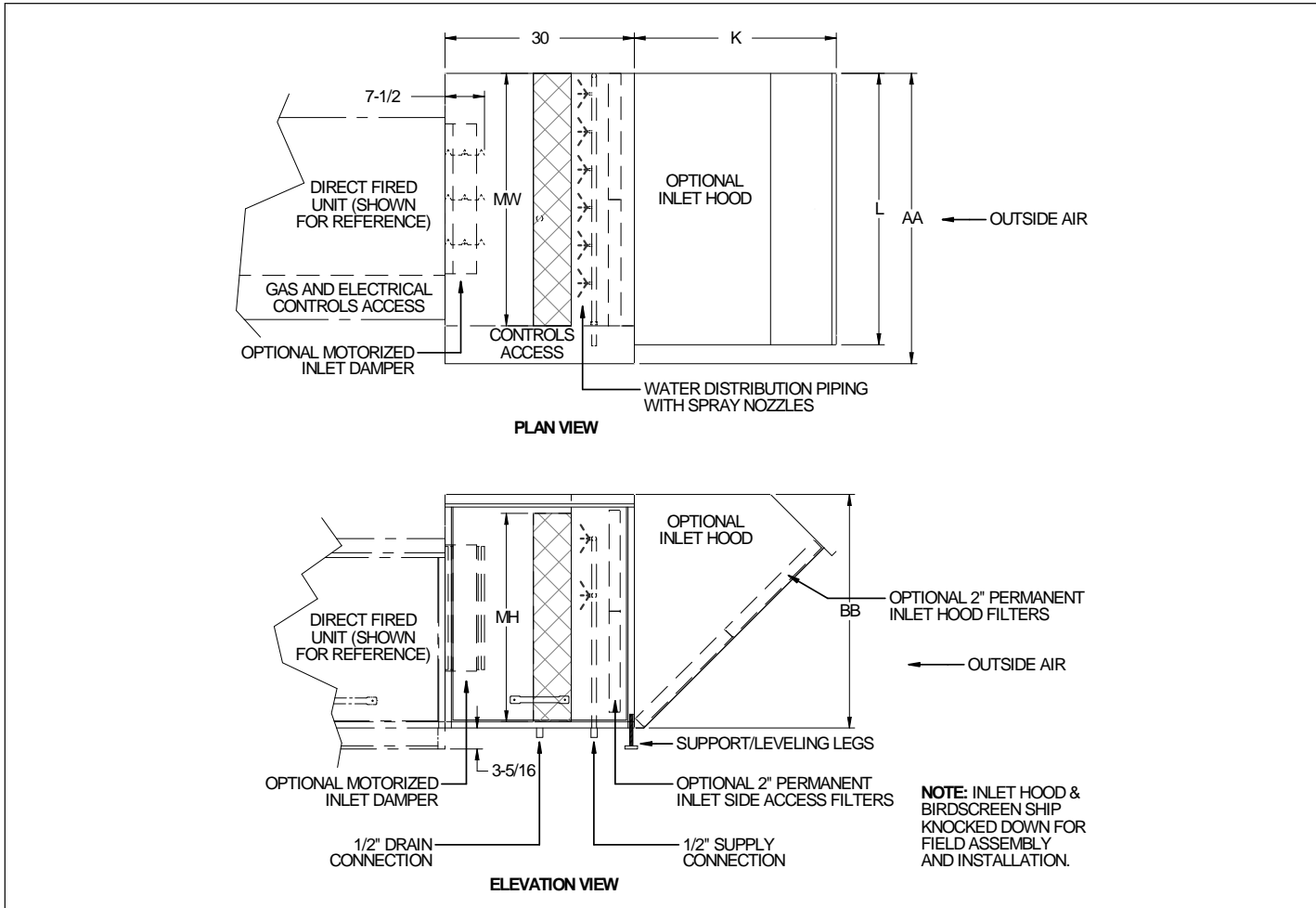

Table 20.1 - Evaporative Cooler Dimensions (inches)

Evap Cooler Model Size	Casing		12" Evap Media			Optional Features					
						Inlet Hood		Inlet Hood Filters		Side Access Filters	
	AA	BB	MH	MW	Media Area (sq. ft.)	K	L	Qty	Size	Qty	Size
EVCNR1	30	28	24	24	4.00	26	28	2	16" x 25" x 2"	1	24" x 24" x 2"
EVCNR2	38	30	26	32	5.78	32	35	4	16" x 20" x 2"	2	16" x 25" x 2"
EVCNR3	46	37	33	40	9.17	32	43	4	20" x 20" x 2"	4	16" x 20" x 2"
EVCNR4	54	44	40	48	13.33	38	53	6	16" x 25" x 2"	6	16" x 20" x 2"
EVCNR5	66	52	48	60	20.00	46	63	9	20" x 20" x 2"	3	20" x 20" x 2"
EVCNR6	66	64	60	60	25.00	58	63	9	20" x 25" x 2"	3	20" x 25" x 2"
										9	20" x 20" x 2"

DIMENSIONS - INLET HOOD AND ROOF CURB



Figure 21.1 - Inlet Hood Dimensions (inches)

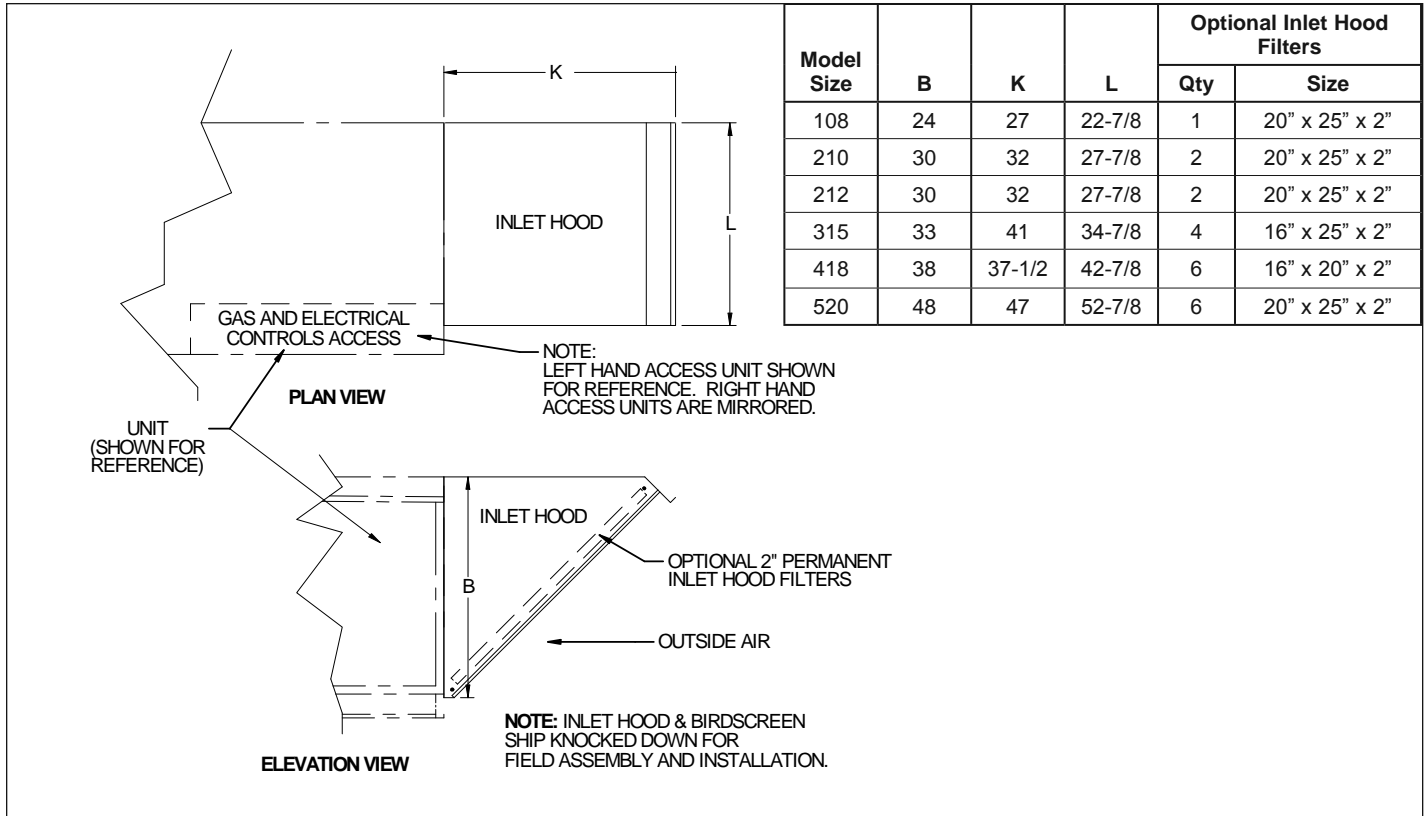
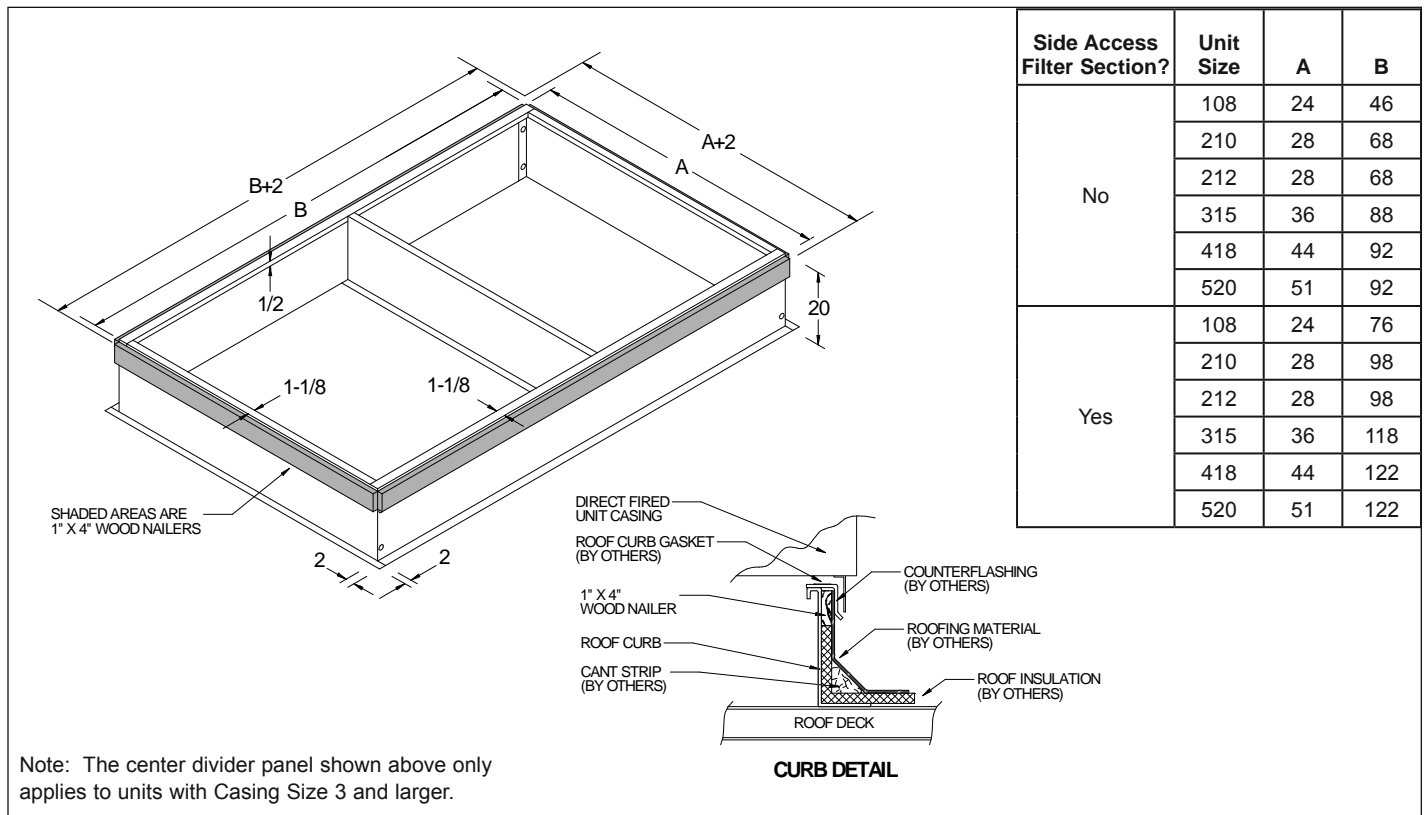

Figure 21.2 - Roof Curb Dimensions (inches)



THIS PAGE INTENTIONALLY LEFT BLANK

THIS PAGE INTENTIONALLY LEFT BLANK

Products from Modine are designed to provide indoor air-comfort and ventilation solutions for residential, commercial, institutional and industrial applications. Whatever your heating, ventilating and air conditioning requirements, Modine has the product to satisfy your needs, including:

HVAC

- Unit Heaters:
 - Gas
 - Hydronic
 - Electric
 - Oil
- Ceiling Cassettes
- Duct Furnaces
- Hydronic Cabinet Unit Heaters, Fin Tube, Convectors
- Infrared Heaters
- Make-up Air Systems
- Unit Ventilators

Ventilation

- Packaged Rooftop Ventilation

School Products

- Vertical Packaged Classroom HVAC:
 - DX Cooling/Heat Pump
 - Water/Ground Source Heat Pump
 - Horizontal/Vertical Unit Ventilators

Geothermal

- Water-to-Water
- Water-to-Air
- Combination

Specific catalogs are available for each product. Catalogs 75-136 and 75-137 provide details on all Modine HVAC equipment.



Modine Manufacturing Company

1500 DeKoven Avenue
Racine, Wisconsin 53403-2552
Phone: 1.800.828.4328 (HEAT)
www.modinehvac.com

© Modine Manufacturing Company 2016